

Copyright © 2024 Shenzhen Pudu Technology Co., Ltd. All rights reserved.

No organization or individual shall imitate, copy, transcribe or translate the contents of this user guide, in part or in full, without the express written consent of Shenzhen Pudu Technology Co., Ltd., or distribute this user guide for profit in any way (electronically or via photocopying, recording, etc.). The product specifications and information provided in this user guide are for reference only and are subject to change without further notice. Unless otherwise specified, this user guide is only intended as instructions for use, and no representation shall be deemed as a warranty of any kind.

1. Safety Instructions

1.1 Electrical requirements

- It is strictly prohibited to use chargers other than the original charger to charge the robot. If the charger is found to be faulty, please replace it as soon as possible.
- Please fully charge the battery to 100% before first use.
- Be sure to charge the robot as soon as it has less than 20% power remaining. Working at low battery levels for long periods will shorten the battery's service life.
- Make sure that the power supply voltage complies with the voltage range on the charger, otherwise the charger may be damaged.

1.2 Use requirements

- Do not block the robot sensor. Otherwise, the robot may fail to move properly or get lost.
- Cleaning or maintenance work is prohibited while the robot is powered on.
- Do not place cookers with naked flames or flammable or explosive items on the robot.
- Do not pick up or place any items while the robot is moving, to avoid property losses or personal injury caused by accidental collisions.
- Do not push or carry the robot while it is moving, to prevent it from running abnormally.
- The robot must not be disassembled or repaired by anyone other than trained professionals. In case of any fault with the robot, please contact a technical support engineer immediately.
- When moving the robot, please observe the requirements on the maximum allowed weight for a single person stipulated by local laws or regulations. While the robot is being moved, please be sure to always keep it in an upright position.

1.3 Environmental requirements

- Do not use or charge the robot in dangerous environments with high temperature, high pressure, or risks of flames or explosions, so as to avoid personal injury or damage to the product.
- Do not use the robot in a humid environment or in the presence of liquid or viscous substances on the ground, so as to avoid damage to the robot.
- Do not use the robot in locations where wireless devices are explicitly prohibited, as this may interfere with other electronic devices or cause other hazards.
- Do not dispose of the robot and its accessories as ordinary domestic waste. Please comply with local regulations on the disposal of the robot and its accessories and support recycling.
- It is necessary to use the robot under the product operating environment declared in this manual. Otherwise, there may be abnormal operation of the equipment or other hazards.

2. Product Components

2.1 Overview

PUDU T300 is a delivery robot applied to material transfer in industrial scenarios and large load handling in commercial scenarios. It is equipped with a load carrier chassis as the core and an operation screen for user-friendly use. The maximum load of the robot can reach 300 kg, and the carrying space is open and flexible, which can be matched with different accessories to meet different carrying needs. Meanwhile, it has rich interfaces, which is convenient for hardware expansion and IOT interconnection.

2.2 Packaging list

Robot ×1, PUDU T300 User Manual ×1, Quality Certificate ×1, Charger ×1.

2.3 Appearance and Components

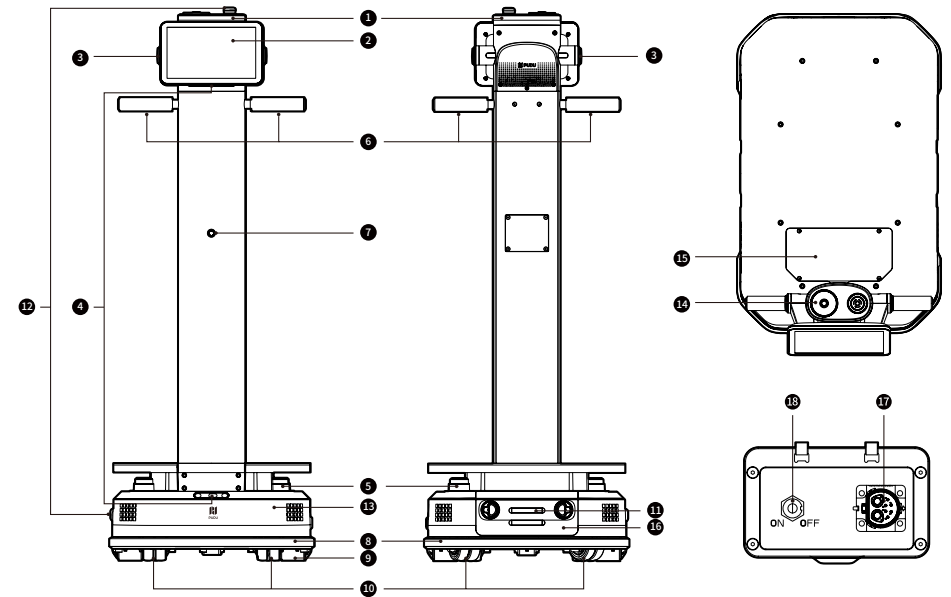

- | | |
|---------------------|----------------------------|
| ① Indicator light | ⑩ Auxiliary wheels |
| ② LCD screen | ⑪ Charging electrode plate |
| ③ Shortcut button | ⑫ Emergency stop switch |
| ④ RGBD | ⑬ Power switch |
| ⑤ Lidar | ⑭ Top view camera |
| ⑥ Handles | ⑮ Interface window |
| ⑦ Front view camera | ⑯ Battery box |
| ⑧ Collision sensor | ⑰ Charging port |
| ⑨ Drive wheels | ⑱ Brake switch |

2.4 Technical specifications

Product Feature	Description	
Operating voltage	DC 20.8 V~29.2 V	
Battery capacity	30 Ah	
Max. load	300 kg	661.39pounds
Charging time	About 2 h (from 0% to 90%)	
Battery life	12 h (None load); 6 h (Max. load)	
Overall weight	65 kg (WTID01); 81 kg (WTIDL1)	143.30 pounds (WTID01); 178.57 pounds (WTIDL1)
Screen specifications	10.1" LCD screen	
Overall dimensions	835 × 500 × 1350 mm	32.87 × 19.69 × 53.15 inches
Cruise speed	0.2–1.2 m/s (adjustable)	0.66-3.94 ft/s (adjustable)
Navigation method	Visual-SLAM, Laser-SLAM	
Min. Path Clearance	60 cm	23.62 inches
Max. surmountable height	20 mm	0.79 inch
Max surmountable gap	35 mm	1.38 inches
Operating system	Android	
Speaker power	10 W × 2 stereo speaker	
Working environment	Temperature: 0° C to 40° C; humidity: ≤ 85% RH	
Storage environment	Temperature: -20° C to 60° C; humidity: ≤ 85% RH	
Operating altitude	< 2000 m	6561.68 ft
Road surface requirements	Indoor environment with flat, smooth surfaces	
Charger power input	AC 100 V~240 V, 50/60 Hz	
Charger power output	29.2 V, 15 A	

3.Product Instructions

3.1 Button description

Powering on:

Move the robot to the startup location. Press and hold the power switch for 3 second, and the Indicator light of the robot will turn blue, indicating that the robot has been successfully powered on.

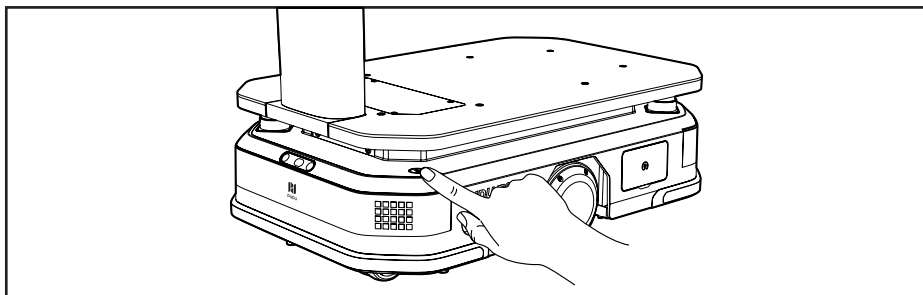

09

Powering off:

Press and hold the power switch for 3 seconds, and a shutdown prompt will pop up. Click "Power off" and the light strip on the top of the robot and the screen will turn off, indicating that the robot has been successfully powered off.

Pause:

While the robot is moving, the current task can be paused by tapping the screen. Tapping the screen again will resume the current task.

Emergency stop:

In case of an emergency while the robot is moving, press the emergency stop switch to stop the robot. Turn the emergency stop switch clockwise and follow the on-screen prompts to resume the robot's operation.

Brake switch:

The brake switch is only used to take effect after the robot has stopped. When the brake switch is "ON", the motor will automatically stop for safety during an emergency stop. If you want to push the robot, you need to set the brake switch to "OFF".

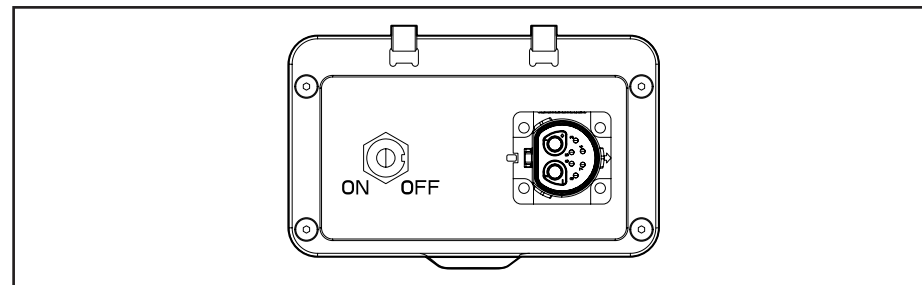

3.2 Charging and Battery Replacement

Charging:

The T300 supports charging with a charger or a charging pile.

- Using charger: Simply insert the matching charger into the robot's charging port to start charging.
- Using charging pile: After deploying the charging pile according to the deployment instructions, start the robot normally. Click on the "Return to Charging" button on the robot's interface to initiate the return to charging process.

Battery Replacement:

When the robot is powered off, open the battery compartment cover. Disconnect the power connector attached to the battery in order to replace the battery. After that, reconnect the power connector and close the battery compartment cover before turning on the robot for use.

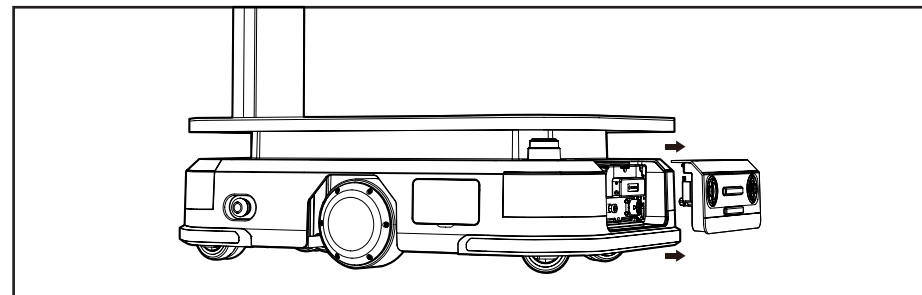

10

3.3 Interface Description

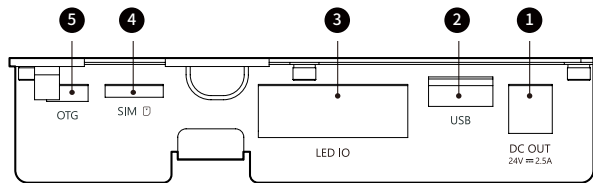

Under the interface window, there are external interfaces that can be used for hardware expansion and device debugging. The specific interface specifications are as follows:

No.	Name	Description
1	Power supply interface	24V (battery voltage), maximum output current of 2.5A. DC plug pin diameter: Ø2.5mm
2	USB	USB 2.0, for data communication with external devices
3	LED IO	Used for LED lights of accessories trays.
4	SIM card slot	Supports Nano SIM card
5	OTG	Used for device debugging

3.4 Mode Introduction

The robot comes with various modes to cater to different scenarios, including Delivery mode, Cruise mode, and Lifting mode.

Mode	Description
Delivery mode	Users can place materials for multiple destinations on the robot and use the screen to send tasks for materials delivery. The robot can plan the best path by itself and deliver the items to all destinations. After the delivery is completed, it will automatically return to the standby point.
Cruise mode	The user can set the path, and the robot will run along the pre-set path in a cycle. In addition, the robot can stop at a stop point on the cruise path, to make it easier for the user to pick up and place materials while the robot is running.
Lifting mode *	Users can set lifting points and lifting down points. The robot will automatically go to the lifting point to identify and lift the materials, and then automatically unload the materials after transporting them to the destination.

The lifting mode is only supported by the WTIDL1 model.

For detailed instructions on using the robot, please refer to the PUDU T300 Operation Guide.

4. Maintenance and Servicing

Part to maintain	Robot status	Checking frequency	Inspection and maintenance method
Drive wheels and auxiliary wheels	Powered off	One week	Please wipe the surface with a clean cloth. Check the wheel surface for wear and replace if necessary.
Visual sensor, and LiDAR	Powered off	One week	Please wipe the surface with a clean cloth. If there is sudden dirt or damage, please handle it in time to avoid blocking the sensor and causing abnormal operation of the robot.
Robot body	Powered off	One month	Please wipe the surface with a clean cloth. And check the installation. Make sure the housing is flat and securely fixed.
Indicator lights and sound	Powered on	One month	Check that all indicator lights and audible warnings are working properly.
Emergency stop switch	Powered on	One month	Check that the emergency stop button is working properly.
Brake switch	Powered on	Six months	Put the brake switch to the "OFF" position and gently push the robot forward to check that the brake switch is working properly. Note: Turn the brake to the "ON" again after checking.
Safety stickers and nameplates	Powered off	Six months	Check that the safety stickers, labels and nameplates on the robot are intact and clearly visible.

For detailed instructions on using the robot, please refer to the PUDU T300 Operation Guide.

5. After-Sales Service

Shenzhen Pudu Technology Co., Ltd. undertakes to provide free product warranty services during the product's warranty period (different parts of the product may have different warranty periods). The customer does not need to pay any fees for the spare parts. Standard fees apply if the warranty period has expired or in cases where free product warranty is not applicable. Customers can call the after-sales service hotline to learn more about the after-sales service policy and for product maintenance, or refer to the PUDU T300 User Guide for detailed after-sales service policies.

Pudu Technology after-sales service hotline: +86 755-86952935, after-sales service email: techservice@pudutech.com.

6. Compliance information



6.1 Disposal and recycling information

The Waste Electrical and Electronic Equipment (WEEE) Directive aims to minimize the impact of electrical and electronic goods on the environment, by increasing re-use and recycling and by reducing the amount of WEEE going to landfill. The symbol on this product or its packaging signifies that this product must be disposed separately from ordinary household wastes at its end of life. Be aware that this is your responsibility to dispose of electronic equipment at recycling centers in order to conserve natural resources. Each country should have its collection centers for electrical and electronic equipment recycling. For information about your recycling drop off area, please contact your related electrical and electronic equipment waste management authority, your local city office, or your household waste disposal service.



Before placing electrical and electronic equipment (EEE) in the waste collection stream or in waste collection facilities, the end user of equipment containing batteries and/or accumulators must remove those batteries and accumulators for separate collection.

6.2 Federal Communications Commission compliance statement

The following information applies to Pudu robotic.

This equipment has been tested and found to comply with the limits for a Class B digital device, pursuant to part 15 of the FCC Rules. These limits are designed to provide reasonable protection against harmful interference in a residential installation. This equipment generates, uses and can radiate radio frequency energy and, if not installed and used in accordance with the instructions, may cause harmful interference to radio communications. However, there is no guarantee that interference will not occur in a particular installation. If this equipment does cause harmful interference to radio or television reception, which can be determined by turning the equipment off and on, the user is encouraged to try to correct the interference by one or more of the following measures:

- Reorient or relocate the receiving antenna.
- Increase the separation between the equipment and receiver.
- Connect the equipment into an outlet on a circuit different from that to which the receiver is connected.
- Consult the dealer or an experienced radio/TV technician for help.

This device complies with Part 15 of the FCC rules. Operation is subject to the following two conditions:

- This device may not cause harmful interference.
- This device must accept any interference received, including interference that may cause undesired operation.

6.3 Federal Communications Commission compliance statement

This device complies with Industry Canada licence-exempt RSS standard(s). Operation is subject to the following two conditions:

- This device may not cause interference.
 - This device must accept any interference, including interference that may cause undesired operation of the device.
- L' émetteur/récepteur exempt de licence contenu dans le présent appareil est conforme aux CNR d' Innovation, Sciences et Développement économique Canada applicables aux appareils radio exempts de licence. L' exploitation est autorisée aux deux conditions suivantes :
- L' appareil ne doit pas produire de brouillage;
 - L' appareil doit accepter tout brouillage radioélectrique subi, même si le brouillage est susceptible d' en compromettre le fonctionnement.